



## **THE LCD ANODIZING SYSTEM**



Copyright 2003 Caswell Inc.  
7696 Route 31, Lyons NY 14489  
(315) 946-1213 <http://www.caswellplating.com>  
**LCD ANODIZING SYSTEM**

**A revolution in Small Scale Anodizing!**

- Provides a hard anodized surface - which can easily be dyed.**
- Simple to operate - Predictable consistent results**
- Low Current Density means – Inexpensive power source**
- Low Current Density means – No heat buildup in the tank**
- VERY dilute chemical requirement – Environmentally friendly**
- No fumes – SAFER in confined areas**
- Fully Expandable - Kits can be made bigger by obtaining larger plastic containers**
- Conforms to Mil Spec A 8625 F**

Standard Kit Contains:

- 6 x 6 gal tanks with locking rings and lids (12" diam x 14" deep)
- 5 tanks for the Anodizing & Dying Process, 1 tank for Anodize Stripping
- 3 x 300 watt x 200 f Ceramic Heaters **NOT INCLUDED**
- 2 x 300 watt x 110 f Heaters **NOT INCLUDED**
- 1 x Rinsing Sprayer
- 1 pack Mist Balls
- 1 x 4oz Mist Suppressant – treats 48 gals of Anodizing Solution
- 1 x 1lb Anodizing Sealant – makes 8 gallons
- 1 x 2lb SP Degreaser – makes 4 gallons
- 2 x 1 qt De-oxidizer – makes 4.5 gallons
- 3 x 8" x 8" GP Plates
- 1 x Air Pump and Airline
- 2 x Titanium Wires
- 1 x Color Wheel
- 1 x .1 ohm resistor
- Full & easy to read instructions
- Requires 1 gallon Battery Acid – not supplied

Deluxe Kit Contains:

- 6 x 6 gal tanks with locking rings and lids (12" diam x 14" deep)
- 5 tanks for the Anodizing & Dying Process, 1 tank for Anodize Stripping
- 3 x 300 watt x 200 f Ceramic Heaters **NOT INCLUDED**
- 2 x 300 watt x 110 f Heaters **NOT INCLUDED**
- 1 x Rinsing Sprayer
- 1 pack Mist Balls
- 1 x 4oz Mist Suppressant – treats 48 gals of Anodizing Solution
- 1 x 1lb Anodizing Sealant – makes 8 gallons
- 1 x 2lb SP Degreaser – makes 4 gallons
- 2 x 1 qt De-oxidizer – makes 4.5 gallons
- 2 x 8" x 8" GP Plates
- 1 x Air Pump and Airline
- 2 x Titanium Wires
- 1 x 1lb Anodize & Chrome Stripper
- 1 x Color Wheel
- 1 x Reverse Osmosis System – produces up to 10 gals pure water per day.
- 1 x 10 amp Rectifier – enough power to anodize 3 sq feet at once
- Full & easy to read instructions
- Requires 1 gallon Battery Acid – not supplied

**THE LCD ANODISING ALUMINUM SYSTEM**

The process of anodizing is, chemically speaking, rather complicated, but in practice is extremely simple.

The process involves placing aluminum in an electrolyte, weak sulfuric acid, and passing a low voltage current through it. The aluminum part is connected to the positive (anode) side and the negative side is connected to a cathode made of lead. This causes the aluminum to oxidize, similar to steel rusting, with the net result of a very hard, tough abrasion resistant protective coating being formed. An interesting 'quirk' of this process is that the film formed looks like honeycomb, and has 'tubes' growing up from the aluminum. These tubes conveniently allow color dyes to flow into them





For the technically inclined, the surface of the aluminum actually grows a layer of aluminum oxide on itself, which is then transformed into aluminum hydroxide (anodize) and finally hydroxide monohydrate. The whole anodize layer is non conductive. The hydroxide is microscopically porous which allows it to absorb dyes. This layer looks somewhat like a honeycomb, as can be seen from this photo, magnified some 40,000 times.

The 'barrier layer' at the base of the pores is thin enough to pass some current, even though the complete layer is non-conductive, so the honeycomb structure continues to grow, as long as current is flowing through the system. The acidity of the solution will also dissolve the anodize, so the latter is only true if dissolution is not faster than growth.

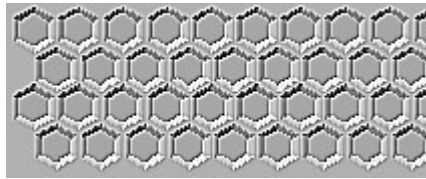

Looking from above

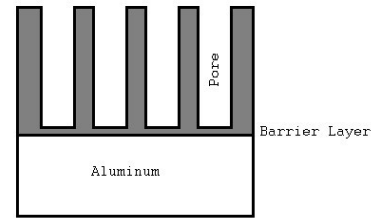

Cross section

Aluminum can be processed in a number of ways to achieve different effects. It may be highly polished to look like 'chrome', brushed with a wire wheel or Abrasive Wheel to provide a 'scratch brushed' finish, or even bead blasted to provide a 'satin' look. All of these processes would be done prior to anodizing, and the surface may, be sealed without dying.

All types of aluminum can be anodized using this process. Very little difference in performance has been noted using all of the more popular alloys.

The most exciting part of aluminum anodizing, is without doubt, experimenting with the amazing array of colors and effects one can produce, with a little practice and skill. The metal can be pretreated in a variety of ways, polished, scratch brushed etc., the anodize film grown, and then the colors applied prior to sealing the anodize surface, permanently locking the colors into the metal.

### Setting up the Anodizing Tank

#### Wiring up the parts.

Anodizing requires special attention to wiring up the parts, because only aluminum parts can be placed into the solution, so the actual wire, must be made of this, or titanium. Consequently, an aluminum wire also is anodized. If a connection is poor, then the anodize film grows on the wire, where it is touching the part, and an insulating barrier is formed, preventing further film growth.

Titanium wire is supplied in all the kits, and can also be obtained separately. Thin aluminum wire may be obtained from almost any garden center/hardware shop. This is ideal for wiring small parts, as long as you make sure you secure the wire mechanically, either by wedging it into a hole or by tightening an aluminum bolt onto it, and into the work piece.

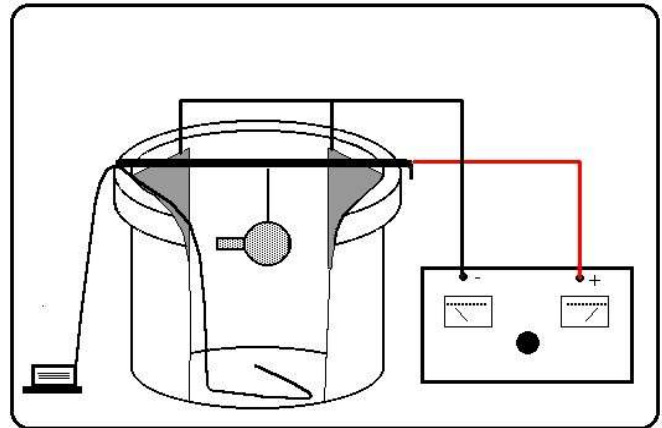

Ideally, the tank bar should also be made plastic. This will avoid corrosion problems and any shorting out due to mists settling on a metal tank bar. A solid bar of plastic could be used, and for the engineering inclined, this could be drilled with holes to accommodate the wire or needle, which could be secured with hex head bolts, tapped into the block.

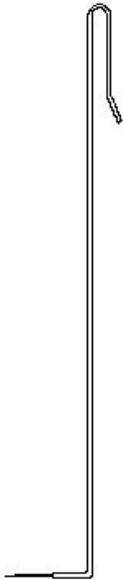

An alternative technique to wire is to use knitting needles. By removing the top of the needle and bending it into the shape needed, it can be forced into a slightly smaller hole, using the needle's tapered point as a wedge.

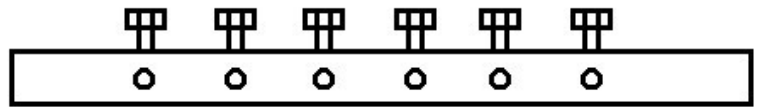

*An aluminum tank bar, using hex head bolts to secure the wire rack*

Aluminum knitting needles are usually anodized, and as this is an insulator, the anodize must be removed, either by sandblasting, abrading with emery paper, or stripping in the anodize stripper. If stripping, leave the needle in the stripper until all the color has gone, usually about 3 minutes. Some needles are coated with lacquer, so you may have to abrade this off.

If you decide to re-use these, you MUST strip off the anodize film every time prior to usage.

Knitting needles (see left) are usually made of harder material and so, when the taper is forced into the hole, it slightly enlarges the softer aluminum, ensuring a tight fit. Soft wire will actually decrease in size if pushed into a work-piece, which is harder than itself, thereby shrinking it, and causing a loose connection.

There is a host of different types of Titanium grips and racking clips available. Titanium is actually better than using aluminum, as it is not anodized in the process, saving you the job of stripping your racks after each operation.

Titanium is also much harder and stronger than aluminum.

Servi-Sure Inc are suppliers of these racks. [www.servisure.com](http://www.servisure.com)

2020 W. Rascher Ave., Chicago, IL 60625 Phone: (773) 271-5900, Fax: (773) 271-3777

Email: [racks@servisure.com](mailto:racks@servisure.com)

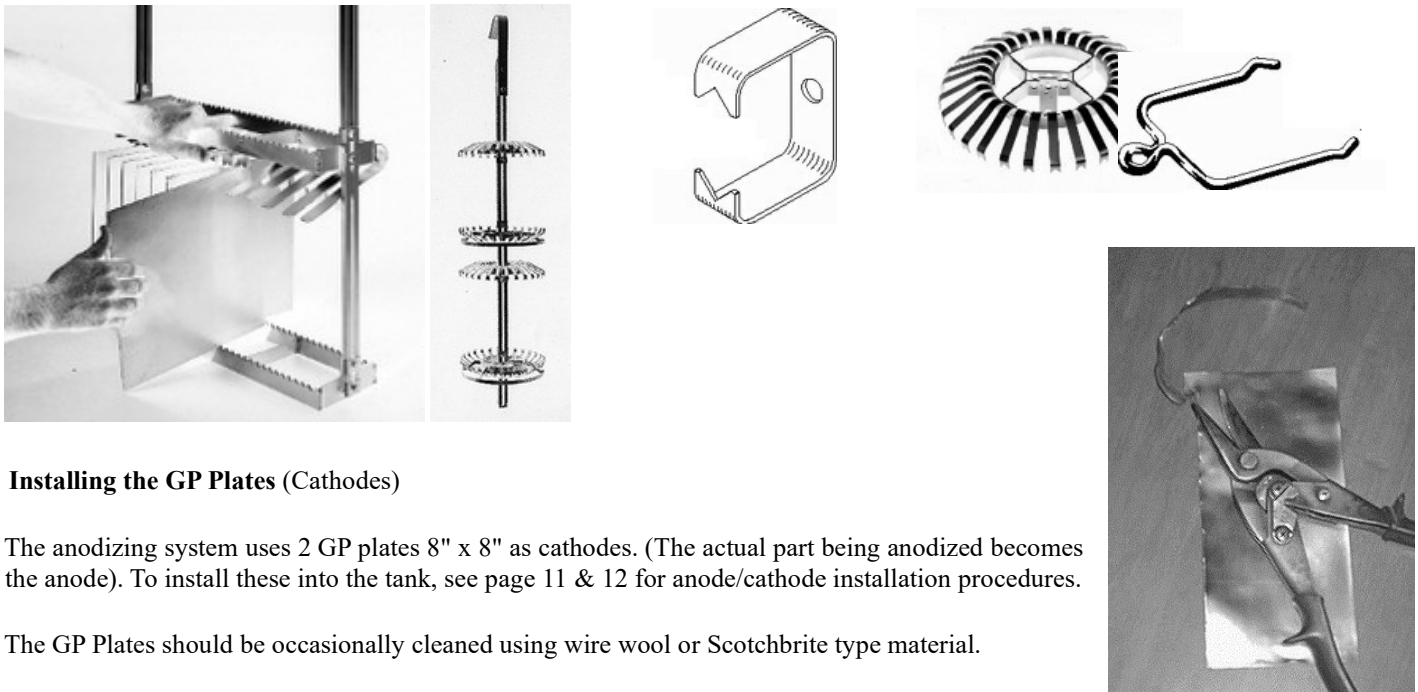

### Installing the GP Plates (Cathodes)

The anodizing system uses 2 GP plates 8" x 8" as cathodes. (The actual part being anodized becomes the anode). To install these into the tank, see page 11 & 12 for anode/cathode installation procedures.

The GP Plates should be occasionally cleaned using wire wool or Scotchbrite type material.

Remove the plates from the solution when not in use.

### CONTROLLING THE POWER

#### The Power Supply and Power Requirements.

Unlike plating, anodizing has the peculiarity of becoming an insulator to itself, cutting off power and stopping further growth of the film. The thicker the film, the more insulated the part becomes from the power supply. There comes a point when a Peak Anodic Resistance (PAR) is reached, when the film will grow no more, and if power is kept being applied, it actually erodes away the film. PAR is quite visible on a rectifier, because the amperage needle drops off. It is therefore useful to install some type of ammeter into

your system, so you can see when you reach PAR. The optimum current requirement is 4.5 amps per sq foot, or 30 milliamps per sq inch. This can easily be supplied from a 12 volt battery and controlled using light bulbs.

See the FLASH VIDEO on [www.caswellplating.com](http://www.caswellplating.com) concerning controlling the power with light bulbs.

**a. Battery chargers**

Battery chargers do a good job on anodizing, but the current still needs to be controlled. Using light bulbs will do this economically. Set the charger to the 12 volt position.

There are some major misconceptions about using battery chargers as power sources. Battery chargers are rated for driving a partially discharged battery, not a grounded load like anodizing or plating. As an example, the voltage was measured and current of a charger under load. This unit was rated for 12V at 10A, when loaded the results were as follows:

- At 0 A (no load) V=13.4 V •
- At 3.66 A (3 Ω) V=11 V
- At 5.35 A (2 Ω) V=10.7 V

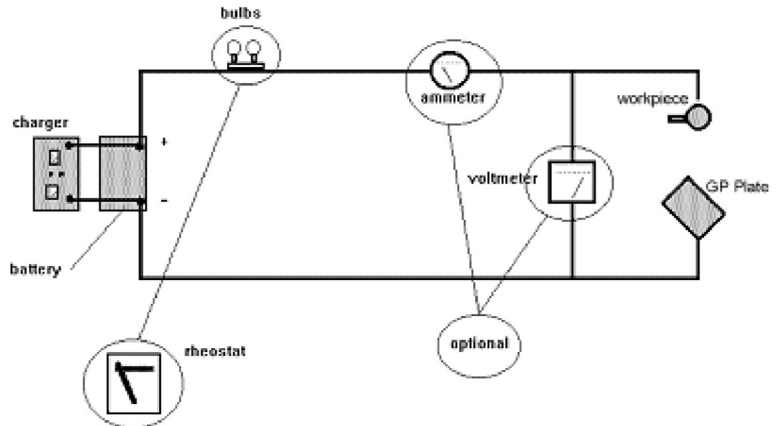

A 10 amp load wasn't tested as it would overheat the charger and open its thermal circuit breaker if operated for any realistic length of time. If this unit were rated as a transformer isolated unregulated power supply, using a full wave rectifier (which is what it is) the rating would be 10.8 V at 5 A. Larger or smaller chargers will scale accordingly.

Besides not putting out the voltage and current that you think you are getting, battery chargers also have no effective means to reduce the voltage and current provided to the load. You can compensate for the first problem by de-rating the battery charger as discussed above, and there is something you can do about the control problem. A perfectly simple way to solve the control problem is to use an ordinary 600 W lamp dimmer to control the input to the charger. This is shown in Figure 6. A charger is a transformer load, not a motor load. The dimmer can power a transformer as easily as it can power a light bulb. The resolution you can actually get isn't great, but it is better than you can get using any reasonable number of power resistors or light bulbs to control the current.

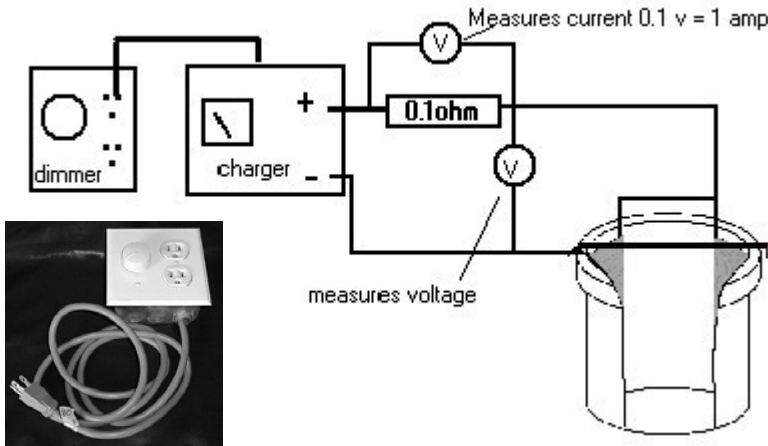

Figure 6. A Variable Voltage Battery Charger Power Supply

**b. Batteries.**

Batteries are not the best power source for anodizing. You are better off using a battery charger controlled with a light dimmer switch. Monitor the current using a multi-meter and a shunt 0.1ohm resistor, as per fig 6.

**c. Rectifiers.**

Rectifiers are the ultimate in anodizing. Variable controls, voltage and amperes dials, allow you to fine tune your anodizing efforts. This can be especially useful when dying, as the minor variations can effect pore size of the anodize, which may interfere with the acceptance of the dye.

**The WATER BREAK TEST**

Also recognised as ASTM-F-22

This test is probably one of the most important procedures in any plating or anodizing operation.

Make sure you carry out this test after doing all the preparation work, including degreasing and etching in pickles.

**To pass the test water will sheet off the part rather than bead off.**

Take a cleaned and dried part and set it in a vertical position.  
Use a spray bottle containing distilled water.  
Spray the part two to three times from at least 6" away.  
If the part is clean and free of oily residue, the water spray should sheet off.  
If some oily residue remains, the water will tend to bead on the part Repeat the cleaning process until the part passes the test.

Alternatively, apply several drops of distilled water to the cleaned surfaces.  
If the surface is inadequately cleaned, the spherical form of the drop is largely retained, and the surface must be cleaned once more.  
If the water runs on the treated surface, then wetting has been satisfactory and the part is ready for plating.

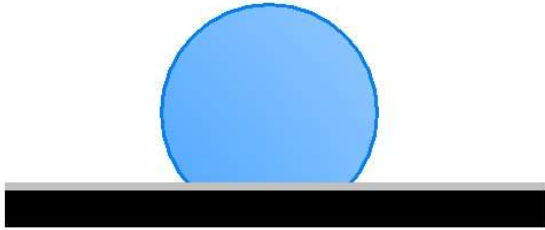

*Oil/dirt film makes water bead up*





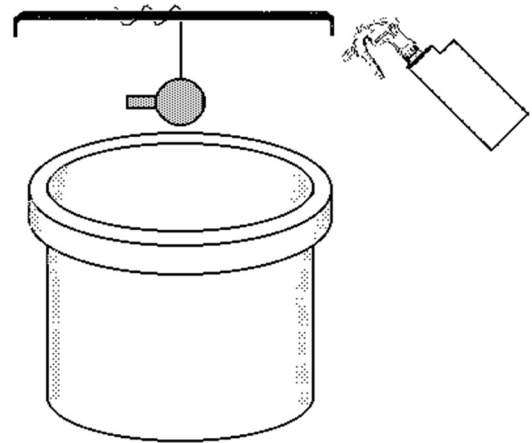

*No oil/dirt film allows water to cover part*

### **RINSING WITH DISTILLED WATER**

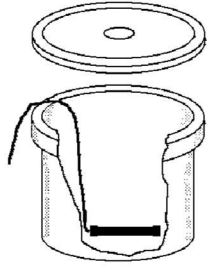
The part should be raised out of the solution and sprayed liberally with distilled water.  
The runoff should be allowed to drain into the tank.

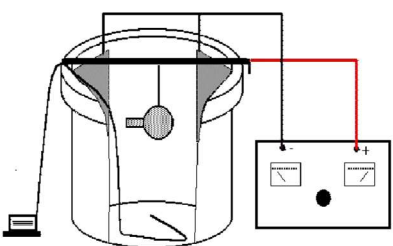

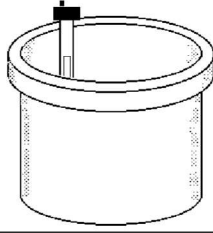
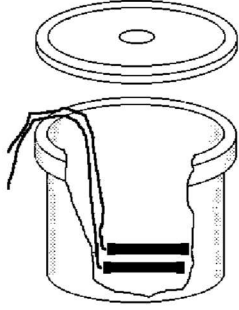
PROCEDURE	SETUP	OPERATING PARAMETERS	EQUIPMENT	SAFETY
1. SURFACE PREPARATION	Buff & Polish for a mirror finish. Bead Blast for a 'flat' finish. Nylon Abrasive wheel buff for a 'scratched brush' look.			
2. DEGREASING		140- 200 deg F No agitation 5 mins immersion  16 oz SP Degreaser 4 gal Distilled water	1 x 5 gal tank 1 x tank lid 1 x lid ring 1 x 200f heater 1 x 2lb SP Degreaser	
1. RINSE IN DISTILLED WATER SPRAY 2. WATER BREAK TEST				
3. ALUMINUM DE-OXIDIZER		110 deg F No agitation 3 mins immersion  4 gal Distilled water 2 x 1 qt De-Oxidizer	1 x 110f heater 1 x 5 gal tank 1 x tank lid 1 x tank ring 2 x 1qt De-Ox	 Wear rubber gloves and goggles
RINSE IN DISTILLED WATER SPRAY				
4. ANODIZING TANK		Ambient temp 60-75F Current at 4.5 amps per sq ft for 90 mins. Agitation 3 gals distilled water 1 gal battery acid (add acid to water) 2 tsp Mist Suppressant	1 x 5 gal tank 1 x tank lid 1 x tank ring 2 x GP Plates 1 x Air pump 1 x air line Mist Suppressant	 Wear rubber gloves and goggles
RINSE IN DISTILLED WATER SPRAY				
5. DYE TANK		110 deg F No agitation 15 mins immersion  2 gal Distilled water 1 x 4oz bottle of Caswell dye Warm water to 180 f before adding dye	1 x 5 gal tank 1 x lid 1 x ring 1 x 110 f heater	
RINSE IN DISTILLED WATER SPRAY				
6. SEALANT		210 deg F No agitation 15 mins immersion  4 gals Distilled water 4 oz Anodizing Sealant  Use mist balls and the lid to retain heat and speed heating. In extreme cold, wrap sides of tank with bubble-wrap & duct tape.	1 x 5 gal tank 1 x lid 1 x ring 2 x 200f heaters Mist balls 1 x 1lb Anodizing Sealant	
RINSE IN DISTILLED WATER SPRAY				

## Aluminum De-Oxidizer & De Smut.

Aluminum De-oxidizer is a concentrated, easy to use liquid material designed to deoxidize and de-smut aluminum prior to anodizing and chromating. Aluminum Deoxidizer is non-chromated, yet offers performance comparable to or better than most chromate bearing products. The product is especially useful on certain types of aluminum alloys found on Japanese motorcycles, which have a certain amount of zinc in them. The presence of zinc makes the casting smut as soon as it enters the anodizing tank. Pre-dipping with Aluminum De-oxidizer reduces this problem.

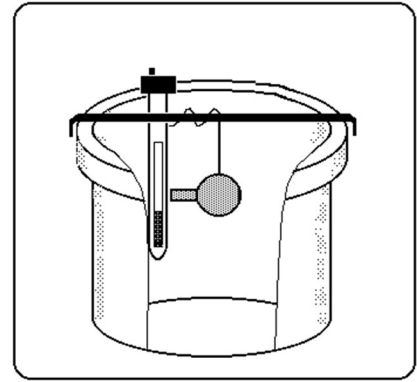

### PRODUCT FEATURES

No chromate disposal problems.

### EQUIPMENT

Tank: HDPE Plastic tanks  
Agitation: Continuous air agitation is recommended to increase effectiveness.

### OPERATING PARAMETERS

Concentration: Mix 1 qt (1 liter) of Aluminum De-oxidizer with 2 gallons water  
Temperature: 70-110°F Optimum 100 deg f  
Immersion time: 1-3 minutes  
Water: De-ionized or distilled



### SOLUTION MAKEUP

Before making up or replenishing the working solution, refer to the Material Safety Data Sheet for protective safe handling measures.

1. Fill tank 2/3 full of water.
2. Add required amount of Aluminum De-oxidizer to the water with mild agitation.
3. Add water to operating level and mix again.
4. 110 deg F

To prevent excessive heat generation and splattering, never add water to Aluminum De-oxidizer. Always add Aluminum De-oxidizer to water. Add in small amounts over the entire surface of the solution with mild agitation.

Dip the parts into the solution for 1-3 minutes, rinse in fresh water, then immediately proceed to anodize the part.

### Operating the Anodizing System.

1. **Check the part for cleanliness.** After thoroughly preparing the part, by bead blasting, polishing etc. ensure it is completely degreased by using the 'water break test'. Simply run water over the part, if the water sheets evenly, then the part is clean. If it 'balls up' or spots, then it needs further cleaning. At this point, the part should already be wired up to the tank bar. This will prevent you from handling it. **DO NOT TOUCH THE PART FROM THIS POINT UNTIL THE PROCESS IS COMPLETE.**
2. **Caustic Etch.** Dip, for a few seconds only, into a room temperature solution of Anodize Stripper, as the etching action will dull the finish slightly. To maintain a bright finish, you may omit this step, however, the part **MUST** pass the 'water break test'. Rinse the part.
3. **Anodizing De-Oxidizer** Dip the part for 1-3 minutes into the pre-mixed solution at 100 deg F. See the section on Aluminum De-oxidizer.
4. **Rinse**, thoroughly in fresh water. Agitate the part, and if necessary, spray with water to rinse chemical from hard to reach areas. A sprayer attached to a faucet is a great idea.
5. **Anodizing the Part.** Place the part into the tank, and connect the tank bar to the positive side of your power supply. Make sure the negative wire is connected to the GP Plates (cathodes). Switch on the power.
6. **General Duration of Anodizing.**  
This is totally dependant on the part reaching PAR, (Peak Anodic Resistance) 1-3 hours Remove the part from the tank and rinse off thoroughly in distilled water.



7. **Acid Neutralizer.** Make up a tank of 1 gal distilled water and 1/2 lb baking soda, as your neutralizer tank. Before proceeding to dying, the part must be completely ridded of acid; otherwise, this will cause you problems. Acid dragged from the anodizing tank into the dye tank will cause streaking and blemishes. It will also eventually alter the dye's color. After neutralizing, rinse in fresh or distilled water.
8. **Dying.** (If a clear anodize is required, skip this part). It is important to try to dye the part as quickly as possible after growing the anodize film, otherwise the pores will begin to close up, and the dye will not be able to penetrate quite so effectively. Dying techniques are covered in a separate section. Rinse in fresh water.
9. **Fixing (or sealing)** Using a plastic tank supplied with the kit, place 1 or 2 gals of water, depending on what will cover the part, and add 1 oz per gallon of ANODIZING SEALANT POWDER, and bring to the boil using the non adjustable ceramic heater. Then place the anodized part into the tank, using the tank bar as the suspension support. Boil for 2-3 minutes per 0.10 mil oxide coating thickness. 24 microns = 1 mil Wipe the parts dry and immediately apply a mineral oil (WD40 etc) with a soft cloth. Alternatively, you could use ANODIZING SEALANT LT which is a liquid. Add to distilled water at the rate of 2 fl oz per gallon. Warm the liquid to approx 85-95 degrees and immerse the part for 10 minutes. Anodizing Sealant LT may slightly effect the color of some dyes, but this is offset usually by the simpler technique.
10. **Cure.** Allow the part to cure in an ambient, dry area for 24 – 48 hours to obtain its final hardness
11. **Polishing.** You may polish the part using a loose cotton buffing wheel and either a white or blue buffing compound. Be sure to take care, the anodize film is not very thick. You could damage it.

## Dying the Anodize

The dying of anodized aluminum is probably one area where artistic creativity can really come to the fore. Limited only by your imagination, parts can be dyed in many ways and colors, to create amazing results. The application of the dye can be done in several ways: simple immersion for a single color, multi immersions for two or three tone effects, air brush painting, silk screen, splash dying etc. etc.

Here, we hope to address all of these techniques, but your best way of getting the most from this process is to EXPERIMENT!

Caswell Inc now carries a range of professional dyes. For a color sample, please visit our web site @ <http://www.caswellplating.com/kits/anodizedye.htm>

These dyes can be mixed together to create a host of different colors. The dyes are in concentrated liquid form, a 4oz bottle makes up 2 gals of ready to use dye. To make up different colors, we suggest that you make up the colors to the correct dilution first, then take a quantity of each dye and blend them together.

A color wheel is supplied with all anodizing kits.

The use of a color wheel will give you a good concept of what to expect when dying, however, **it does not represent our dyes specifically.**



The Color Wheel shows how the three primary or parent colors (the only colors that cannot be made by mixing two others) relate to each other. The wheel clearly illustrates the results of color mixing. For example, equal amounts of two primary colors (red, yellow, or blue) create secondary colors (orange, green, or purple).

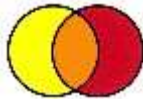

Yellow + Red = Orange

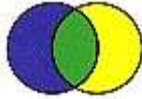

Blue + Yellow = Green

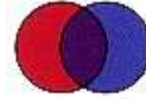

Red + Blue = Violet

Anodizing dyes are transparent, so this means you can 'overlap' colors, just as in the diagram above. The dye colors also mix well, which allows plenty of variety in 'mix 'n match' dying. When over-dying, consideration must be given to the color wheel, red and yellow = orange, blue and yellow = green etc. These colors are adjacent to each other on the wheel. However, if you try to dye across the wheel, eg: yellow & violet, or blue and orange etc, you will get only shades of brown. Dying green over red gives you black or brown.

Dyes are designed to operated at 140 deg F, however, we have found most of our dye will work at room temperature, providing you are using our new parameters for power and attaining PAR. Some variation in shades may occur.

### COLOR MIXING

You have some choices when it comes to creating new colors.



**You can premix the dyes.** This involves some experimentation to get exactly the right color.



**You can over-dye.** Starting with the lightest color, simply dip the part in, rinse off, then dip into the next color, and so on. Using this technique, you can easily see exactly what is happening, and you don't waste your original colors by premixing.



**Toning a dye color.** Various shades can be created by dipping the colored anodize into a black dye.



**Shades of color.** The duration of dipping time will lighten or darken the overall color of the dye.

### COLOR APPLICATION

There are an almost infinite number of ways you can apply dye to anodized surfaces.

- Immersion. ○ Full immersion to produce one solid color ○ Partial Immersion to produce two or more colors ○ Over dying by immersion.



#### Direct Application

- Air Brush (see right) ○ Paint Brush ○ Syringe ○ Eye Dropper ○ Sponge
- Splash or spill over ○ Silk Screen
- The dye may need to be thickened. This is accomplished using the following materials:

Water 1000 parts  
 Corn Starch 75 parts  
 Tapioca Starch 25 parts  
 Gum Tragacanth 225 parts

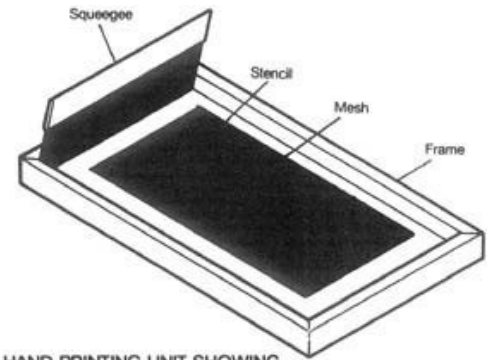

HAND PRINTING UNIT SHOWING 4 BASIC COMPONENTS OF SCREEN PRINTING.

Add this mix @ 20% to 80% of the dye depending on the consistency required. There is a huge potential for silk screen work in the decoration of aluminum for road vehicles. In particular, the motorcycle and Hot Rod enthusiasts would love to see the large areas of aluminum, such as side covers, with more permanent decoration. By using a silk screen process, and starting with the lighter colors, several colors could be screened over the aluminum, to create full color logos etc. Pastel dyes could be used as a background color. A good example would be a side cover from a Harley motorcycle. Dip it in the gold dye first, then screen on the orange of the Harley logo, and finally screen on the black element of the logo. The part would need to be set in a jig of some sort, to ensure the logo colors are printed in the correct places. A little 'Imagineering' and a small production run could easily be set up.

#### MASKING OFF

There may be areas where you want the original color of the metal to show through, yet total immersion would spoil the effect, or you may want to create patterns in the over dye or subsequent colors. To prevent dye from affecting these areas, a number of 'masks' can be used, such as: masking tape, Avery Labels, clear contact paper, rubber cement, grease pencils, etc. Liquid masks can also be applied using a simple silk-screen process. Grease pencils will be removed in warm water. Check the melting point of the pencil.

#### REMOVING DYE

You may find that a mistake has been made on your work-piece, perhaps the color is wrong, whatever the reason, you have to remove some, or all, of the dye. As long as the part has NOT been sealed, most dyes will easily be removed by immersing in household bleach. We've found that our black dye (the most dense color) whites out in about 1 minute with a splash of bleach. Rinse the part thoroughly afterwards in room temperature water (not hot, or you will start to seal the anodized surface). You may apply the bleach with a brush, or a cotton swab, or you may even fully immerse the part.

**MAKE SURE YOU DO NOT ACCIDENTALLY DROP BLEACH INTO ACID, (e.g. the anodize tank), AS THIS CREATES CHLORINE GAS DANGEROUS FUMES!**

If the part has been sealed, then you can immerse it in ANODIZE STRIPPER to remove all the dye along with the anodize film. Of course, after doing so, you'll have to re-anodize the part.

## SEALING THE ANODIZE WITH ANODIZING SEALANT

High Temperature Sealant. (Do not confuse this with room temperature LT system, which may allow some colors to leach out slightly.)

A plastic tank and a special ceramic heater (right) are supplied for sealing. This heater will boil the solution. **DO NOT LEAVE UNATTENDED** or the solution will boil away and the tank may ignite.



Do **NOT** use aluminum or any metal container, as it causes problems.  
Always use distilled water, as ordinary water may leave mineral deposits on/in the film.

Anodizing Sealant is a nickel acetate compound for sealing anodic coatings on aluminum. It is a fine flowing greenish powder, readily soluble in water and specifically formulated with a pH regulator and an agent to help minimize smut. Anodizing Sealant is suitable for clear anodize and offers increased weather and light-fastness on coatings dyed with aluminum dyes.

### OPERATING PARAMETERS

Make up a solution of: 1 oz per Anodizing Sealant to 1 gal of distilled water - or 7.5 grams per liter  
Time: 5 to 30 minutes depending on anodize thickness (2-3 minutes per 0.10 mil. oxide coating thickness) 24 microns = 1 mil.

Temperature: 202-210°F  
pH: 5.5 to 6.0  
Water: De-ionized or Distilled water

### CONDITIONS FOR USING ANODIZING SEALANT

**Tank:** Sealant solution should be contained in a plastic tank.

**pH:** pH adjustments will not be necessary unless acidic or alkaline compounds are carried over into this sealing bath. Add acetic acid (to lower pH) or ammonia (to increase pH). Acetic acid is difficult to come by, and it is preferable to discard the bath, especially as it has a limited shelf life anyway. White vinegar is a good substitute.

**Rinse:** Before sealing, a **LIGHT** rinse is necessary to remove any foreign substances. After sealing, the work should be thoroughly rinsed at once, as is normal in nickel acetate sealing, before it is dried.

#### **Filtration**

Filtration clears the bath of precipitates with interfering action. Filter through coffee filters after each use.

**Maintenance.** Bath life is 14-60 days dependent upon operating conditions and bath upkeep.

### BATH TURBIDITY

Freshly prepared nickel acetate sealant baths are clear green solutions. In use they become contaminated by precipitates and grow cloudy. If not removed, these contaminants can form deposits on the sealed surface. The effect can be due to the following: High pH (at pH values above 6.0, nickel acetate may be converted into soluble nickel hydroxide), hard water and trapped impurities.

The following measure can be taken to minimize this affect: Maintain pH value of  $5.7 \pm 0.3$ , through rinsing of anodized, dye or undyed work prior to sealing to prevent possible introduction of contaminants and filtration to clarify the bath and to prevent surface deposit formation

### ANODIZING SEALANT LT

Here is a great new product which eliminates the need for boiling to seal the anodize.

This remarkable material seals in only 5-10 minutes. Simply add 2 fl oz per gallon of distilled lukewarm water.

It works by penetrating the pores of the anodized surface and through a precipitation mechanism plugs the pores to provide an anodic film with improved corrosion resistance.

Seals at only 90°F. Can be used on clear, electrolytically colored and most dyed finishes.

### OPERATING PARAMETERS

Concentration: 1.7%-2.0% by volume  
Time of Immersion: 5 to 10 minutes  
Temperature: 88°-92°F pH: 5.8-6.1  
Fluoride Concentration: 550-650 ppm

## CONDITIONS FOR USING ANODIZING SEALANT LT

**Tank:** Stainless steel or lined steel, or plastic.  
**Water:** Deionized. Distilled **Heat:** Use Aquarium heaters.

**pH:** Lower with 10% sulfuric acid. Raise with small, slow additions of 50% sodium hydroxide. Do not allow the pH electrode to sit in the sample for any length of time. Fluorides in the bath will cause damage.

**Rinses:** Rinse Thoroughly prior to sealing. Use good quality water and overflow at adequate rate to maintain low ion concentrations. A clean high quality rinse after sealing will eliminate dry-on stains, water spotting and powdering.

**Agitation:** Agitation is needed for make-up and additions. No agitation is required for normal operation.

**Filtration:** As Anodizing Sealant LT bath ages, a small amount of particulate matter will form on the work if not removed by filtration. The seal tank should be filtered 2-3 times per week, using a coffee filter. Lower the pH to 4.5-4.8 before filtering the seal bath.

## SEAL TEST

Parts sealed with Anodizing Sealant LT will pass a dye stain test immediately after drying, but require at least 6 hours to pass the modified dye stain test and 24 hours to pass the acid dissolution test (ADT). Full curing occurs in approximately 30 days. This curing can be accelerated by a 150°F DI water rinse for 5 minutes and will pass the ADT once the work piece dries.

## BEHAVIOR OF DYEING IN LOW TEMPERATURE SEALING

Field experience has shown that the use of a fluoride sealant can lead to leaching of the dyed parts during the sealing process. Anodizing Sealant LT compatibility with aluminum dyes should be confirmed by users own test.

## TYPICAL PROCESS CYCLE

1. Clean SP Degreaser.
2. Spray Rinse
3. Dip Rinse
4. Deox/ desmutt using deoxidizer.
5. Spray Rinse
6. Anodize
7. Spray Rinse
8. Dip Rinse
9. Dye (Rinse
10. Spray Rinse
11. Seal in Anodizing Sealant LT
12. Warm water rinse at 150°F

## STRIPPING THE ANODIZE FILM

Mix up a solution of 4-6oz of Anodize & Chrome Stripper with 1 gal of water. Add the powder slowly to the water.

Dip the anodized part into the solution for between 20 seconds and 10 minutes, depending on the thickness of the existing anodize film.

Rinse off the part thoroughly in fresh water.

**TESTING FOR ANODIZE FILM CONTINUITY** (see overleaf) and if present re-immers.

Ideally, the solution should be at approx 70 deg F plus. The hotter the solution, the more rapidly the anodize film will be stripped. Solution temperature range is 70-150 deg f.

Use only plastic vessels, not aluminum, as this material is extremely corrosive to this metal.

**TESTING FOR ANODIZE FILM CONTINUITY**

Anodize film is non-conductive, whereas the actual aluminum is conductive. It is therefore relatively easy, using a multimeter, to determine if we indeed have grown an anodize film. Set any multimeter to the 1000 ohm setting.

Place the black and red probes on the aluminum in different places. The needle on the multimeter dial will swing over if there is NO anodize film. If you have grown an adequate film, then the multimeter will not register at all.

The work must be perfectly dry to do this test.

Test does not show ADEQUATE GROWTH, but only that there is SOME growth of film.



**Some Interesting Points about Anodized Aluminum.**

Anodized aluminum has a very durable surface that is unaffected by weather and many chemicals. The surface will resist high temperatures, even a blowtorch, for short periods. Many other types of dye may be used with varying effects, fabric dye, leather dye, water-based ink, felt tip pens etc.

Anodized films are usually measured by their intended operation:

Interior or unexposed articles	0.1 - 0.2 mil (mil = 1/1000")
Auto Trim	0.2 - 0.4 mil
Architectural or construction	0.8 -1.0 mil

Once a part has been anodized, it cannot be reshaped, and any great degree of flexing will cause the anodize film to crack.

Sharp edges can create problems, because the anodize pores grow out at right angles to the metal. On the example here, the corner area is almost completely void of pores. This will show up when dyeing.

MIL SPEC A-8625F calls for a 1/32" minimum radius on corners, when applying a 1 mil anodize film.

Consideration needs to be given to this phenomenon, and sharp edges should be rounded over.

Pore diameter and barrier film thickness will vary depending on the voltage and the electrolyte temperature. Different alloys will also have different effects. Pore size is related to current density, higher volts means smaller pores. Generally speaking, the larger the pore, the easier the dye will take.

**TROUBLESHOOTING ANODIZING**

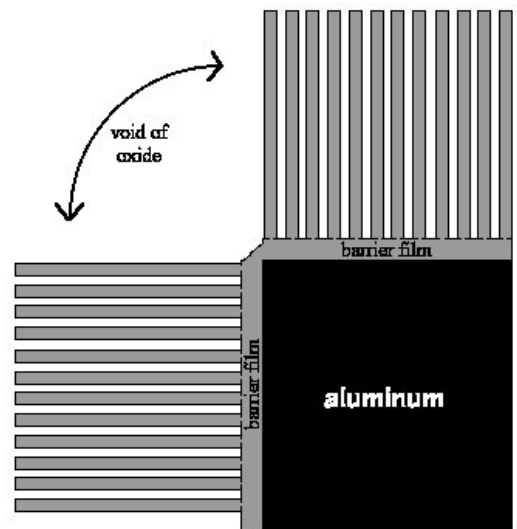

FAULT	PROBABLE CAUSE	REMEDY
Decrease in depth of color	Bath contamination	Improve rinsing
	Dye used up	Extend dying time Replace bath

Color depth changes in a production run	Anodizing film is inconsistent	Improve conditions to ensure constant procedure
Color differences	Irregular current in anodizing procedure  Different alloys	Clean contacts  Dye only similar alloys
Darker edges	Irregular current density and heat building up film	Reduce current/heat Lower dye temp and dye for longer period
Large cloudy areas	Anodizing temp not uniform	Increase agitation
Pale spots	Oily  Uneven wetting of the parts when dyeing impurities  Local overheating by polishing  Gas bubbles on anodize pores	Add 2 drops liquid detergent Immerse in the wet state only. Agitate the parts in the dye bath. Re-anodize -briefly  Agitate parts. Increase agitation.
Dark Spots	Over heavy dyeing, superficially attached particles	Reduce dyeing temp & extend dyeing time.  Clarify dye bath by filtering.
Dull &/or chalky dye (probably won't wipe from surface.	Inadequate anodize, too soft. Current free suspension in anodize. Coating attacked by low anodize bath pH.	Reduce anodize temp/time &/or acid concentration. After switching off current, remove parts & rinse off. Increase PH to 4.
Opaque & dull coating, removed by wiping.	Excess of hydrolyzed aluminum.	Replace dye bath. Acid dip part prior to dyeing to dissolve & clear aluminum.
Surface pitting & soft coating	Part too close to the cathode	Increase tank size &/or move part further away

### ANALYZING DYING PROBLEMS

Questions to ask	Main Reasons parts fade:
<ol style="list-style-type: none"> <li>1. What dye was used?</li> <li>2. What was dye-bath concentration, pH and temperature?</li> <li>3. What was the oxide coating thickness?</li> <li>4. How long was the part dyed?</li> <li>5. What sealant was used? At what concentration, temperature, pH and time?</li> <li>6. Were the parts cleaned, etched and deoxidized prior to anodizing?</li> <li>7. Does the faded part have exposure to light from a window?</li> <li>8. Does the part get hot?</li> </ol>	<ol style="list-style-type: none"> <li>1. Wrong type of dye used.</li> <li>2. Parts not dyed long enough.</li> <li>3. Oxide coating too thin.</li> <li>4. Poor sealing.</li> <li>5. Parts exposed to high temperatures.</li> <li>6. Interior parts were dyed with wrong type of dye and placed by a window.</li> </ol> <p>99% of the time, the cause is dye time (too short), poor sealing and too thin oxide coating. Please remember, just because a dye may have a good rating for light fastness, it does not mean that it will have an unlimited life expectancy.</p>

### Sulfuric Acid Concentration

Most conventional sulfuric acid anodizing is carried out using electrolyte concentrations ranging from 165-225 g/l free sulfuric acid. An increase in the sulfuric acid concentration intensifies re-dissolution of the coating, producing a pore structure of greater average diameter allowing dyeings of greater intensity. It is most important to maintain the free sulfuric acid concentration within narrow limits to ensure successive dyeings of equal intensity. **Aluminum Content**



dyeing quality, and the higher currents favor surface hardness. Anodizing has both the virtue and curse of being a highly analog process; almost everything is a matter of degree. There is no one set of operating conditions that will optimize all parameters.

There is an old adage in Engineering; “good, fast, cheap, select any two”. Operating at low current density provides “good” and “cheap” at the expense of “fast”. Trading off process speed may not be such a good choice if you are anodizing commercially and “time is money”, but small scale anodizing by definition concerns only one or a few items to be processed at a time.

Low current density operation provides these advantages:

- Much lower equipment costs; high output current power sources are completely avoided. • Much lower maximum required voltage; the required peak voltage does not exceed 7.5 V at 3 A/ft<sup>2</sup> or 15 V at 6 A/ft<sup>2</sup>. It doesn't matter if you are anodizing 1 square inch or 1 square mile, the peak voltage remains the same. This also translates to much lower equipment costs.
- No heat build up; the actual power the work dissipates in the electrolyte is so low, cooling and temperature maintenance can usually be ignored.
- Less sensitivity to agitation requirements; the hydrogen liberated is spread over a much longer time.
- Less susceptible to connection degradation; since the electrical current is lower, the electrical connection to the work is under less attack by the action of the anodizing process.
- Less or no fuming; the current is low, so the anodizing is slower, liberating less acid fumes and mist.
- Generally safer operation; less of everything that can do damage.

Low current density operation provides these disadvantages:

- The available surface hardness is lower than standard current density operation; but still hard enough for the majority of applications. It is still far harder than any type of paint known and most chemical deposition finishes.
- The process takes longer than standard anodizing.

### **Closed Loop Current Control**

The method described here is a departure from the traditional open-loop voltage source method used for decades by amateurs and professionals alike. “Open-loop” means it is largely uncontrolled, relying on a strict set of parameters to be met if any consistency is expected. Since the scope here is amateur anodizing, many of these parameters are not understood or measurable by the amateur anodizer. Worse still, little of the available literature is in any agreement.

The closed-loop current source method used has the virtue of being “closed-loop”, many parameter variations are now self compensating by the use of electrical feedback. The practical advantages of non-critical temperature, electrolyte concentration and volume, cathode material and size, anodizing current and voltage, anodizing time, and alloy of the work are obvious. High uncontrolled currents at startup are also avoided, which makes the process much safer.

### **The Power Source**

The Industry still uses the archaic term “rectifier” to describe the power source for anodizing or plating. If you actually have a working knowledge of electricity let alone an electrical engineering degree, it is obvious that a current source, rather than a voltage source, is the ideal type of power source to use. This is the case for ease of use and quality of the results obtained.

A voltage source provides a preset voltage to the load, and varies the current as necessary to maintain that voltage. A current source provides a preset current and varies the voltage to maintain that current. All laboratory power supplies made in the last 30 years, and nearly all professional “rectifiers” will operate in either mode.

### **Current Source Anodizing and the Concept of PAR**

Current source anodizing uses a preset current to do the anodizing. The voltage applied is whatever is necessary to maintain the preset current. As the anodic layer forms, its electrical resistance increases, if the applied voltage does not increase proportionally, the current will decrease proportionally. Ohm's Law strictly governs this:

$$V = I \times R$$

Where: V is the voltage applied

I is the current flowing

R is the electrical resistance

The process works like this. The current source is preset to the desired current. The work is then connected to the current source and power is applied. The voltage applied is automatically very low, because the resistance of the work is very low. As the anodizing barrier layer forms, the resistance increases, and the current source responds by increasing the voltage. This process continues as a slow and

orderly increase in voltage until the resistance of the anodic layer stops increasing or the current source reaches its maximum voltage, whichever occurs first. This Peak Anodic Resistance (PAR) is dependant on anodic layer thickness, and is weakly dependent on time and on the aluminum alloy being anodized, as well as other anodizing process parameters.

It is important to understand that the actual value of PAR seen is inversely proportional to the area or the work. For example: If the work has a surface area of 1/2 ft<sup>2</sup> and has a resistance of 5 Ω. The resistance would be 2.5 Ω if the surface area of the work was 1 ft<sup>2</sup>. Because of this, PAR has the dimensions of The Reciprocal of Ohms per Square Foot (1 / Ω/ft.<sup>2</sup>).

If the process is allowed to continue after PAR is reached, PAR will start to decrease, again in a slow and orderly manner. The current source responds by decreasing the applied voltage to maintain the preset current. The PAR point is detected by noting when the voltage stops increasing, and starts to decrease.

It is not generally known outside of the Industry that anodizing involves two electro-chemical reactions that are competing with each other; the growth of the anodize layer, and the action of the sulfuric acid dissolving the anodize layer, this second reaction is called “dissolution”. The object is to grow it faster than it is dissolving. This is why PAR decreases after it reaches its peak value. The electrical resistance of the anodic layer is proportional to its thickness, this permits real time assessment of anodizing thickness while the process is operating. This assessment allows the operator to take corrective action if the process is not proceeding as expected.

### The Practical Application of Current Source Anodizing

The current source itself is the only equipment difference between voltage source and current source anodizing. The easiest to use and most convenient available current source is an ordinary laboratory adjustable power supply. These can be operated as current sources if they have a constant current operating mode, and most do. If the power supply has a current meter or readout and a current adjustment knob, it is generally capable of constant current operation. Specifications such as line and load regulation, output noise, and absolute accuracy are of little consequence when anodizing, and can be ignored. Suitable used power supplies are available on Ebay and elsewhere for as little as \$20.

It is possible to detect PAR when using a voltage source. This requires the operator to monitor the voltage and current, adjusting the voltage when the desired current is not flowing. PAR will be detected when the voltage must be adjusted down for the desired current, and not up. Fortunately, anodizing is a slow process; human response time to adjust the voltage is a non-issue for practical anodizing. Unfortunately, for the lower anodizing currents, the process is so slow it will test the anodizer’s patience if peak detection is done manually.

The traditional amateur method of hooking up a voltage source (battery charger, car battery, etc.) with no current limiting and “letting it rip” is the dominant source of anodizing outright failures or poor results. This immediately damages the electrical connections within the first few milliseconds after startup. Don’t do it.

### PAR and Various Aluminum Alloys

Figure 1. shows the measured anodizing voltage of three common aluminum alloys over time.

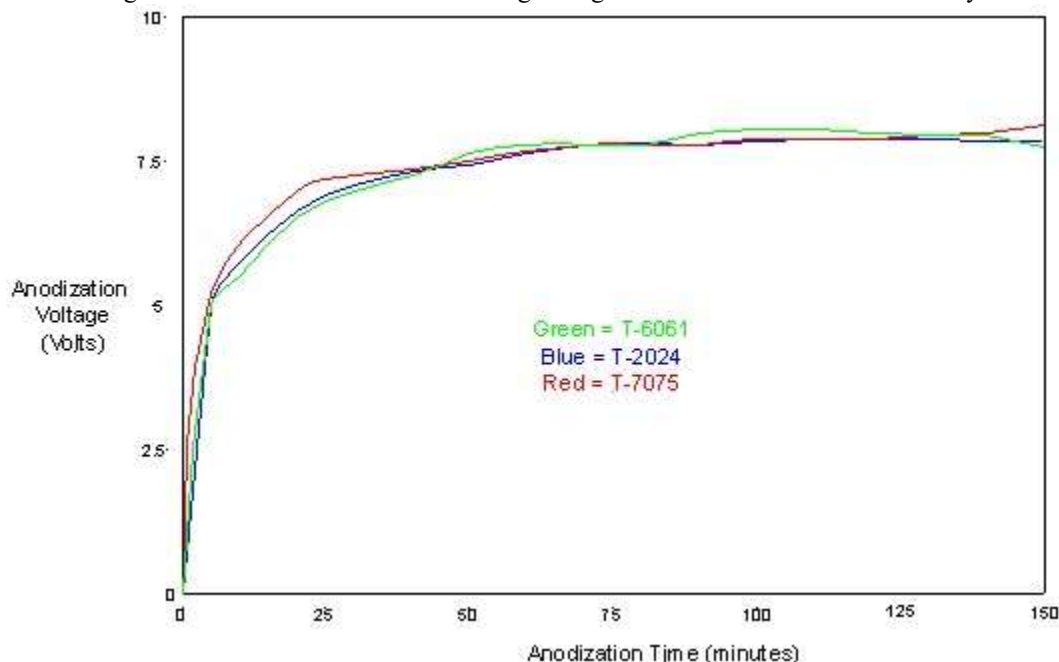

Figure 1. Anodizing Curves For various Alloys at 3A/ft

All three samples were 12.0 in.<sup>2</sup> (1/12 ft<sup>2</sup>) surface area, and the anodizing current was 3 A/ft<sup>2</sup>. In this case PAR would be:

$$\text{PAR } (\Omega) = V \div I = 7.5 \text{ V} \div .25 \text{ A} = 30\Omega \text{ (for 12.0 in.}^2\text{)}$$

To express PAR in ohms per square inch (in.<sup>2</sup>):

$$\text{PAR (in.}^2\text{)} = \text{PAR} \div (1/\text{Area}) = 30\Omega \div (1/12 \text{ in}^2) = 360 \Omega / \text{in}^2$$

Since there are 144 square inches in a square foot:

$$\text{PAR (ft}^2\text{)} = \text{PAR (in.}^2\text{)} \div 144 \text{ (in}^2\text{/ft}^2\text{)} = 2.5 \Omega / \text{ft}^2$$

This value, 2.5  $\Omega / \text{ft}^2$ , will change a little as other operating parameters change. Because of this an exact value of PAR for a given anodizing current cannot be provided. Figure 1. serves to show that the value of PAR varies weakly with alloy type, at least for the three tested.

### PAR at Various Current Densities

Figure 2. provides the anodizing curves for T-6061 alloy at five current densities.

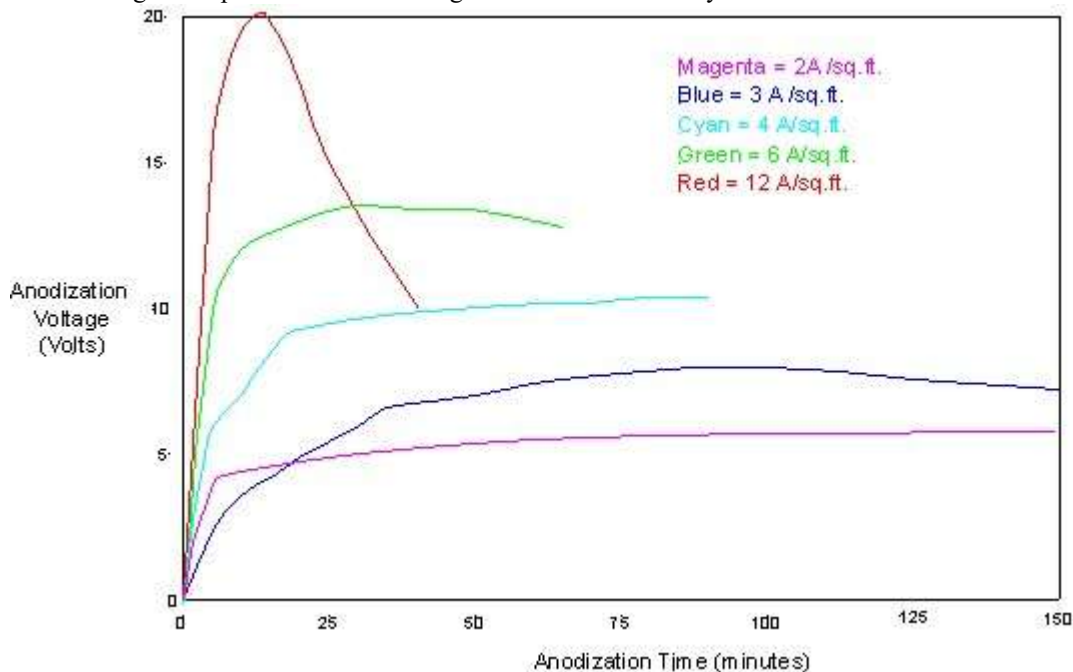

Figure

2. Anodizing Curves for various Current Densities

The 12 A/ft<sup>2</sup> curve peaks at a much higher voltage than the others, and shows a pronounced peak. The 6 A/ft<sup>2</sup> curve also has a well defined peak. In this graph more data was averaged together for the 3 A/ft<sup>2</sup> data, and a peak and a decline in the voltage is observed. The 4 A/ft<sup>2</sup> curve would also show a peak and decline if the anodizing was run longer. The 2 A/ft<sup>2</sup> curve will take perhaps 3 hours or more to peak, but it will eventually.

### Elapsed Time to PAR

The time to PAR shown in the above graphs is unique to this setup, when run under these operating conditions. The room and electrolyte temperature was about 70 deg. F. The value of PAR is only slightly temperature dependant. If your parameters are not the same, the time to PAR you show will be a bit different than mine. There is no harm in this; this is how the closed loop nature of this method compensates for parameter variations.

The Expected Peak Voltage if  $PAR = 2.5\Omega$

Figure 3. has lines added to indicate what the expected peak voltage would be if PAR is equal to  $2.5 \Omega/\text{ft}^2$ .

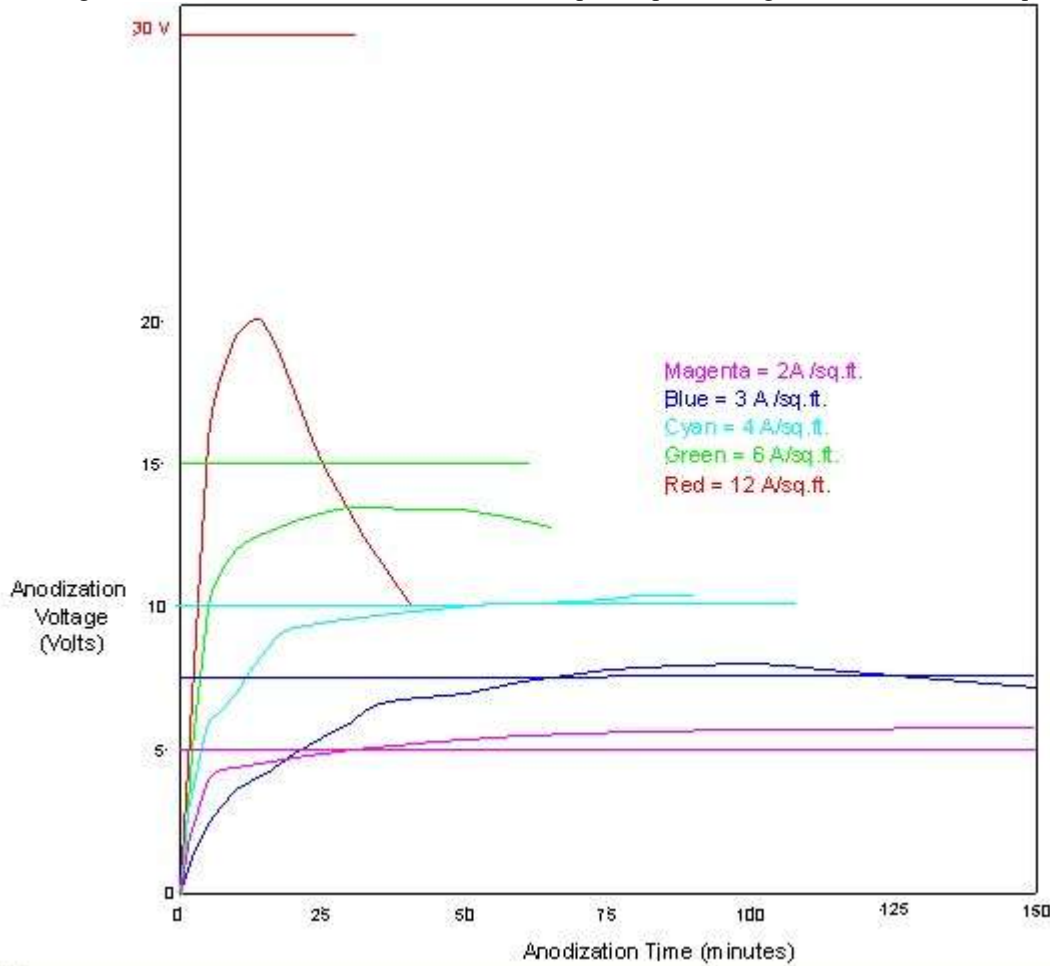

Figure 3. Figure 2. with Calculated Peak Voltage Targets Added

Note that the three lower current densities all meet and slightly exceed the expected voltage. The  $6 \text{ A}/\text{ft}^2$  curve got to about 90% of the expected peak voltage. The  $12 \text{ A}/\text{ft}^2$  curve is only about 2/3rds. of its expected peak.

Many more controlled experiments would need to be done to determine if ' $PAR = 2.5\Omega$ ' is actually valid for the higher current densities. Inspection of the test samples shows that the samples that did reach the expected peak voltage have thick anodic coatings that are very uniform and dyed very well. Judging by the sample for  $6 \text{ A}/\text{ft}^2$ , 90% of the expected peak is enough to provide good results. The  $2 \text{ A}/\text{ft}^2$  sample has a thick coating but dyed poorly because of its excessive pore size. If a means were provided to stop the rapid dissolution of the anodize layer on the  $12 \text{ A}/\text{ft}^2$  sample, it too would have had a thick anodize coating. Retarding the dissolution reaction so that the correct peak voltage can be reached is probably how Type III (hardcoat) coatings are grown.

**Current Density and Pore Size**

It is well documented in numerous anodizing books, that higher current density provides smaller pore sizes, which produce harder coatings that are harder to dye. The reverse is also true. The  $2 \text{ A}/\text{ft}^2$  sample shows poor dyeing because the pores are too large and the dye runs out during sealing. Sealing itself becomes a problem, dye or no dye. The coating is also soft for aluminum oxide. Because of this, set  $3 \text{ A}/\text{ft}^2$  as the lower limit for low current density anodizing.

**Equipment Set Up**

The photo right shows an anodizing setup.

Figure 4. Anodizing Setup

## Anodizing Tank

Rubbermaid Brand polycarbonate container for the tank, rated as 5 gallon capacity, and measures 18”L x 12”W x 9”D. The 3 gallons of electrolyte fills it to 4” from the top.

## Cathode

The cathode may be nearly any alloy of aluminum, lead, or titanium. Any contact with the electrolyte of any other metals must be avoided. For no other reason than its apparent widespread use, the cathode is made from hardware store 0.012” thick aluminum flashing. This material has a tough plastic coating on it that must be removed. Failure to do this will result in a sticky plastic sludge floating in the tank after a few hours, This coating is resistant to even pure Acetone, and must be thoroughly sanded off. For my tank, a piece of the flashing measuring 38”L x 8”W was cut and fitted so that it ran across the bottom, and up over both short sides. The flashing was bent over the tank rim to keep it in place. This method allows the use of ordinary alligator clips for the cathode connection because it is not in the electrolyte. The cathode area in my tank was 1.5 ft.<sup>2</sup> per side, counting only the cathode area in contact with the electrolyte. Contrary to popular myth, it does no harm (or good) for the cathode area to exceed the area of the anode (the work) but the reverse will promote cathode shadow defects in the work.

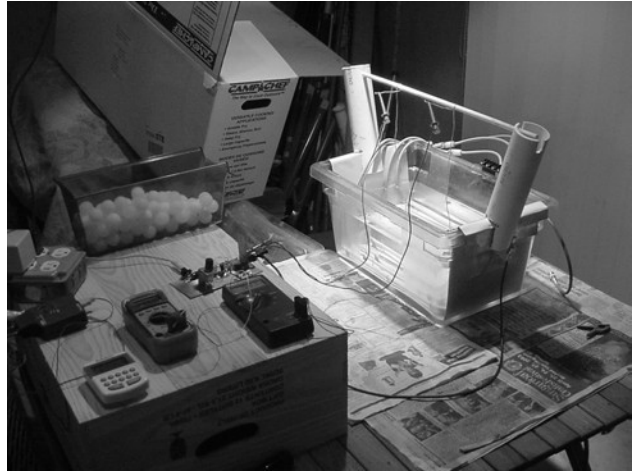

## Electrolyte

A new batch was prepared for these experiments; the solution was 3 quarts of NAPA brand battery acid added to 9 quarts of distilled water, for a total of 3 gallons of electrolyte. The 1:3 ratio by volume that is recommended is much weaker than the previous electrolyte mix, but slightly stronger than Industry standard (about 1:3.5 by volume). It will be much safer and easier to live with than the previous mix.

Scholle Corporation, who manufacturers this battery acid for NAPA, rate their product:

- 3.71 lbs. concentrated sulfuric acid / gallon
- 10.55 lbs. distilled water / gallon
- For a total weight of 14.26 lbs. / gallon.
- Concentration by weight (not volume) is 35%
- Specific Gravity is 1.265 as it comes from the NAPA container.

## Agitation or Aeration System

Some type of agitation must be used during anodizing to remove the hydrogen bubbles that form during the anodizing process. These bubbles tend to stick to the work (anode) and the cathode and can partially block the anodizing because they are both electrical and thermal insulators. If this is not done, you will have uneven anodizing.

Agitation is actually moving the electrolyte around so that the bubbles are washed off by the electrolyte itself. It works on the cathode as well as the anode (work). This is done with an acid rated recirculating pump taking out electrolyte from one side of the tank and then replacing the electrolyte on the other side. This also has the virtue of promoting even tank temperatures.

Aeration uses lots of small air bubbles to knock the hydrogen bubbles off of the work, it will also de-bubble the cathode if the air bubbles can reach it. Aeration is simpler to do because the electrolyte is not removed from the tank. Aeration causes more acid mist than agitation, this mist can be effectively suppressed by using Caswell mist balls and the Anodizing Mist Suppressant.

The “agitation system” was simply shaking the bubbles off of the work every few minutes. What was yet easier was to momentarily lift the work out of the electrolyte and then re-immers it. Do this slow enough not to splash electrolyte. If a current source is being used, it automatically ramps up and down the voltage to accommodate this momentary open circuit, and no harm is done.. When the work is out of the electrolyte, the bubbles are immediately released. Doing this with a voltage source is inviting drawing an arc, which will leave a permanent surface defect. The bubbles on the cathode were ignored because it is large enough to not be appreciably blocked.

For these experiments, a small-scale aeration system was constructed that has proven to be very effective. The construction and operation details are provided in the Appendix.

## Test Samples

All samples are commercial bar stock and are known to be the alloy presented. There are two sizes of aluminum test samples that were used in this project, a single 24 in<sup>2</sup> sample, two 12 in<sup>2</sup> and seven 10 in<sup>2</sup> samples. There are more anodizing experiments than samples provided because early on some were stripped and used again. It became clear that stripping the anodizing was too time consuming, so

this practice was stopped. The connection hardware in all cases was T-2024 aluminum hex head bolts and T-2024 aluminum hex nuts. The thread was ¼ x 20 TPI. The test samples have two ¼ x 20 TPI holes 0.25” deep to accept the hardware. Each hardware connection (1 bolt and 1 nut) was calculated to have 1.00 in<sup>2</sup> of surface area. Two hardware connections are used on each sample to provide redundant electrical connections to insure accurate data. Including the hardware, each test sample is 12.0 in<sup>2</sup> total. The hardware must be included as surface area because it was anodized with the sample. The single large square sample is 26.0 in<sup>2</sup> including the hardware. All samples have identifying stampings on a flat side or one of the ends. The surface area of the anode wires was neglected after calculation showed that the surface area of the wires exposed to the electrolyte was negligibly small.

### Sample Surface Preparation

In all cases, the test samples were sanded after machining, degreased, and then bead blasted twice, once after sanding and again immediately before anodizing. The hardware was bead blasted once. Each sample was rinsed to remove blasting dust and de-smutted at 140 deg. F. for two minutes with Caswell De-smut. Rinsed again and anodized. The two 14 AWG soft aluminum anode wires were bolted to the sample before de-smutting. The wires were not bead blasted but were de-smutted as part of the assembly. A reasonable attempt was made to insure that all samples had the same degree of surface texture.

### Anodizing

All samples were anodized suspended by their redundant anode wires in the center of the tank, 3 inches minimum from any cathode surface. Aeration was started within 1 minute of applying power.

### Dyeing

All samples were dyed with Caswell HBL black dye at 140 deg. F. for 30 minutes. In many cases it was obvious that 10 minutes dyeing time would have been entirely enough. A new batch of the dye was used in these experiments, mixed to Caswell’s instructions.

### Sealing

All samples were sealed by immersion in tap water at a hard boil (before immersion) for 10 minutes.

### Sample Post Treatment

No sample has any grease, oil, wax, WD-40, or anything else applied to enhance the final surface appearance. The only post treatment applied was rubbing them down with a paper towel to remove any remaining dye on the surface.

### Sample Individual Descriptions

The photo below shows the test samples photographed in bright sunlight.

The test samples are presented in the order that they were anodized in. The samples that were stripped and redone are shown here in their final form.



Figure 5. Test Samples

ID#	Date	I/ft <sup>2</sup> (A)	V <sub>PK</sub> (V)	PAR (Ω/ft <sup>2</sup> )	T <sub>PAR</sub> (Min.)	T <sub>TOTAL</sub> (Min.)	Comments
A 24SQ B	8/8/03	6	15	2.4	20	46	1
A 12SQ B	8/9/03	12	20	1.6	15	15	2
A 12SQ 2B	8/9/03	2.5	6.3	2.5	70	70	3
6061 5	8/13/03	6	13.44	2.24	36	66	4
6061 3	8/14/03	3	8.01	2.66	120	150	5
7075 1	8/15/03	3	8.09	2.70	180	245	6
2024 1	8/16/03	3	7.80	2.60	155	210	7
6061 4	8/18/03	4	10.32	2.58	90	90	8
2024 2	8/18/03	2	5.80	2.92	150	185	9
7075 2	8/19/03	3	7.46	2.52	40	150	10

Table1. Test Sample Data

## Comments

1. T-6061 square bar stock, re-anodized, originally done 8/7. Deliberately run past PAR by slowly increasing the current to 12 A/ft<sup>2</sup>. This reduced the anodic layer to 77% of PAR. Cathode shadow is due to HW being too close to the sample surface. Aeration was two 14" Aquarium "air stones" at 5 PSI each (10 PSI total).
2. T-6061 square bar stock, re-anodized, originally done 8/8. Redone to verify 12 A/ft<sup>2</sup> results. The black "plugs" are the remnants of HW sheared off during removal after the 1<sup>st</sup>. anodizing. Dyeing is poor, but the surface is very hard. Aeration was 2 14" Aquarium "air stones" driven by a large aquarium air pump.
3. T-6061 square bar stock, first attempt at low current density. The dyeing is better than the 12 A/ft<sup>2</sup> attempts, but not good enough. Aeration was 2 14" Aquarium "air stones" driven by a large aquarium air pump
4. T-6061 7/8" diam. Cylinder. This sample was deliberately run past PAR until the anodic layer was 98.4% of PAR. Dyeing is excellent, anodize thickness is moderate, and the surface is quite hard. Aeration was four 14" Aquarium "air stones" at 5 PSI each (20 PSI total). Aeration now appears adequate. This sample was the 1<sup>st</sup>. to use the "junk box" VCCS, which now makes the data 10X more accurate.
5. T-6061 7/8" diam. Cylinder, re-anodized, originally done 8/11. This sample was the 1<sup>st</sup>. test done at 3 A/ft<sup>2</sup>. The dyeing is excellent, anodize thickness is excellent, surface hardness is moderate. The dyeing was remarkably easy and fast.
6. T-7075 5/8" diam. Cylinder. This sample was the 1<sup>st</sup>. test done with 7075. This sample reached equilibrium at 180 minutes. The anodizing did not decrease as the anodizing time was run past PAR. The rate of change became so small that all that was being seen was the long term drift in the test equipment (about 1 mV per minute). The dyeing is excellent, anodize thickness is excellent, surface hardness is moderate. The dyeing was also remarkably easy and fast
7. T-2024 5/8" diam. Cylinder. This sample was the 1<sup>st</sup>. test done with 2024. This sample did reach equilibrium. When this anodizing was stopped, the sample still showed 99.6% of PAR. The dyeing is excellent, anodize thickness is excellent, surface hardness is moderate. The dyeing was also remarkably easy and fast
8. T-6061 7/8" diam. Cylinder, re-anodized, originally done 8/12. This sample was done to test at a current density of 4 A/ft<sup>2</sup>. Dyeing is moderate, anodize thickness is moderate, and the surface is quite hard. Note the nick in the anodized layer, caused by a wrench slipping when removing the HW.
9. T-2024 5/8" diam. Cylinder. This sample was done to test at a current density of 2 A/ft<sup>2</sup>. The dyeing and color uniformity is inferior to 3 A/ft<sup>2</sup>. It appears that the pore size is now getting too large and dye retention and sealing will now start to become a problem. The peak voltage required stays below 6 V. It also takes too long to do.
10. T-7075 5/8" diam. Cylinder. This sample was done at 3 A/ft<sup>2</sup> but with no aeration or agitation at all. The pale spots and uneven color indicate that some type of aeration or agitation is required for good results.

## Conclusion

Low current density has been shown here to be a practical method for amateur and small- scale anodizing, particularly if dyeing characteristics instead of mechanical wear resistance is to be optimized. The very slow PAR this method exhibits would favor an electronic method for peak detection; circuits have infinite patience, humans have very little.

## Appendix

This section contains useful bits of information that don't fit elsewhere in this document. They are presented in no particular order.

### Hydrogen Released During Anodizing

Also contrary to popular myth, the amount of hydrogen released in small scale anodizing is far too little to pose any sort of a fire, explosion, or health risk.

## The Scientific Theory and Mathematical Techniques Used

All of the science applied to do this work did not exceed 8<sup>th</sup> grade basic electricity. The only exception might be the current source material, which is college undergraduate engineering. The mathematics in no case got beyond 7<sup>th</sup> grade basic Algebra. Anything beyond this is simply not needed here. The value of PAR at any time the process is operating is nothing more than noting the voltage measured, and dividing it by the anodizing current, Ohms law again.

If  $V = I \times R$ , then  $R = V / I$

When the anodizing process is stopped, and the work is removed, dyed and sealed, the conductive path through the anodize barrier layer is lost permanently. The electrical resistance will now appear very high, and electrical measurements are no longer practical.

### Anodic Layer Thickness Measurements

Two attempts were made to measure the thickness of the anodic layer, neither worked with the equipment available. The first was to measure the thickness of the work before and after anodizing. The layer thickness would then be  $\frac{1}{2}$  of the difference between the two measurements. 1<sup>st</sup> attempt used a electronic digital micrometer, which can measure ten thousandths of an inch accurately, it didn't work because it could not be certain that it measured the work in the same place both times. The second attempt involved weighing the sample before and after anodizing, similar to the procedure described in MIL-A-8625F, which is the US military specification for anodizing. This didn't work either because my scale would only measure to 0.1 grams. The mil-spec coating weight for samples of the size used here would be about 0.07 grams minimum.

### Using Light Bulbs as Power Resistors

This "poor man's power resistor" is a century old trick. Although the stability is not too good, it's good enough for simple current limiting at higher currents. 12V automotive bulbs and sockets to hold them are cheap and available at any auto parts store. If the bulb is rated for voltage and wattage, its resistance will close to:

$$I = W / V, \text{ then } R = V / I$$

The power dissipation rating will be the original Wattage rating. If the bulb is rated for voltage and current (Amps):  $R = V / I$

The power dissipation rating (Watts) will be:  $W = V \times I$

120 VAC light bulbs will have too high a resistance to useful for these purposes. For example; a 100 W, 120 VAC light bulb will have roughly 144  $\Omega$  of resistance, the higher the wattage, the lower the resistance.

### A Small Current Source

For these experiments a small (up to 1 A) but very accurate Voltage Controlled Current Source (VCCS) was built out of junk that was lying around to provide the power. Voltage and current was monitored by using two cheap (but accurate) digital voltmeters. Not shown in the picture is a 15V 800 mA power cube from an HP printer. The wires have banana plugs attached to the ends to connect to the two digital voltmeters that measure voltage and current.

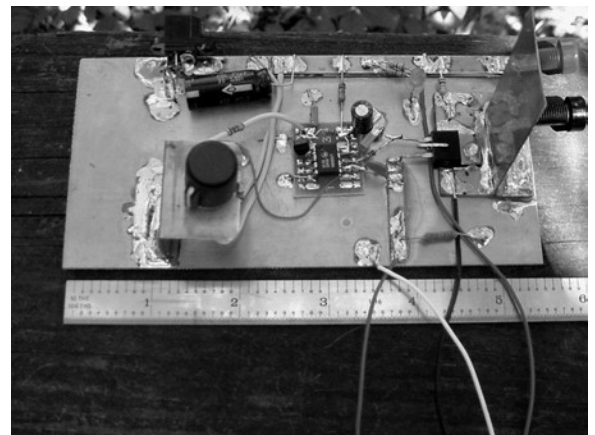

Figure 7. 1 Amp "Junkbox" VCCS

The measured performance of this circuit using the 15V 800 mA. power cube, but excluding the cheap voltmeters was:

- Current Regulation; +/- 0.01% from 0 to 1A.
- Absolute Accuracy; +/- 0.5% from 0 to 1 A.
- Voltage Compliance; 12 V min. for 0 – 1A current range.
- Long Term Stability; better than 0.1% over a 3 hr. time period.

This degree of precision is not needed for anodizing, but it is inherent in this type of circuit. A lower performance circuit could be designed, but it wouldn't be any cheaper. The cost to build was low. It could be duplicated with Digi-Key parts ([www.digikey.com](http://www.digikey.com)) for about \$10, excluding the power cube.

### Radio Shack Current Sense Resistor

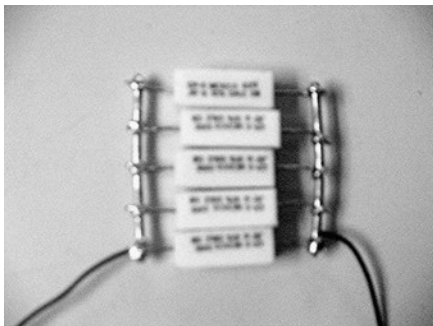

You are going to be tempted to use the ammeter function in your cheap digital multimeter to sense the anodizing current directly. Be forewarned, the amps scale on cheap meters can only be used for short periods of time before blowing their fuse, if it even has one. You can put together a suitable current sense resistor by using five Radio Shack 0.47Ω 5W power resistors in parallel. This results in a close to 0.1Ω 25W resistor. You will be reading amps /10 with this (1A = 0.1V). A 1Ω resistor will drop 5V if you are drawing 5A through it. The picture below shows the construction details of the Radio Shack current sense resistor. The heavy wire on each end was stripped out of 14/3 romex home wiring cable, anything 16 AWG or larger will do. At this low a resistance the resistor leads should be soldered, don't even think about wire nuts.

Figure 8. Radio Shack Sense Resistor

### A Small Scale Aeration System

This is the aeration system used for this project. The air source was the air compressor used for bead blasting. It has an oil trap in the air line to prevent any compressor oil from contaminating the electrolyte. The outlet pressure is set to 5 PSI per "air stone", which is 20 PSI total in my case. Do not hit these "air stones" with 100 PSI, that will literally blow them out of the tank. The "air stones" are all- plastic aquarium Topfin brand "Bubble Walls", 14" long and 1/2" in diameter. Do not use regular air stones; they will dissolve in the acid. The tubing is regular aquarium tubing. One-way aquarium flow valves are used to prevent acid from siphoning into the air supply. The aquarium 1:4 manifold with individual adjustable valves to distribute and regulate the air flow is of all plastic construction. Avoid any metal aquarium parts. It is necessary to wire the aerators firmly to the bottom of the tank so that they

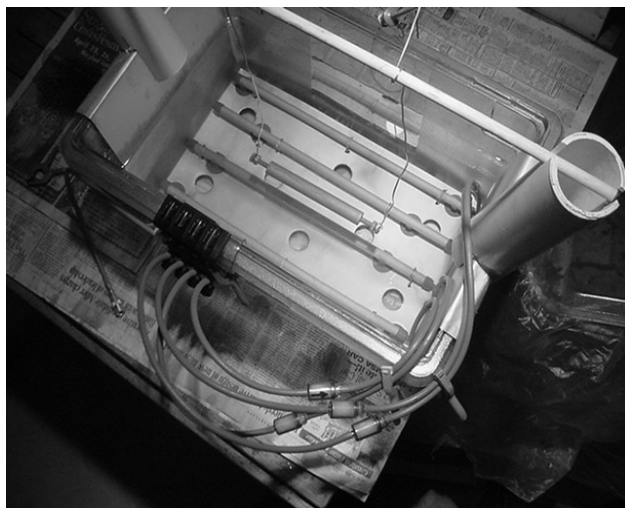

don't move around, with aluminum wire of course. The bottom running cathode is handy for this. The large holes in the cathode allow the electrolyte to escape when removing this assembly from the tank. For satisfactory aeration, it is necessary to have the aerators cover the entire bottom of the tank. The following picture shows the details of the aeration system.

The pieces of PVC plumbing pipe elevate the dowel that the work hangs from to about 9" above the electrolyte. This is to avoid the dowel from being wetted by electrolyte mist and providing a sneak path for the anodizing current. Mist balls certainly help, but this measure is good practice. The cylinder suspended in the tank is one of the test samples ready for anodizing.